

**HELI**  
LIFTING THE FUTURE

**1.2-1.6 ton**  
**CDD12-CDD16**  
**AC ELECTRIC PALLET STACKER**





**Load Curve**

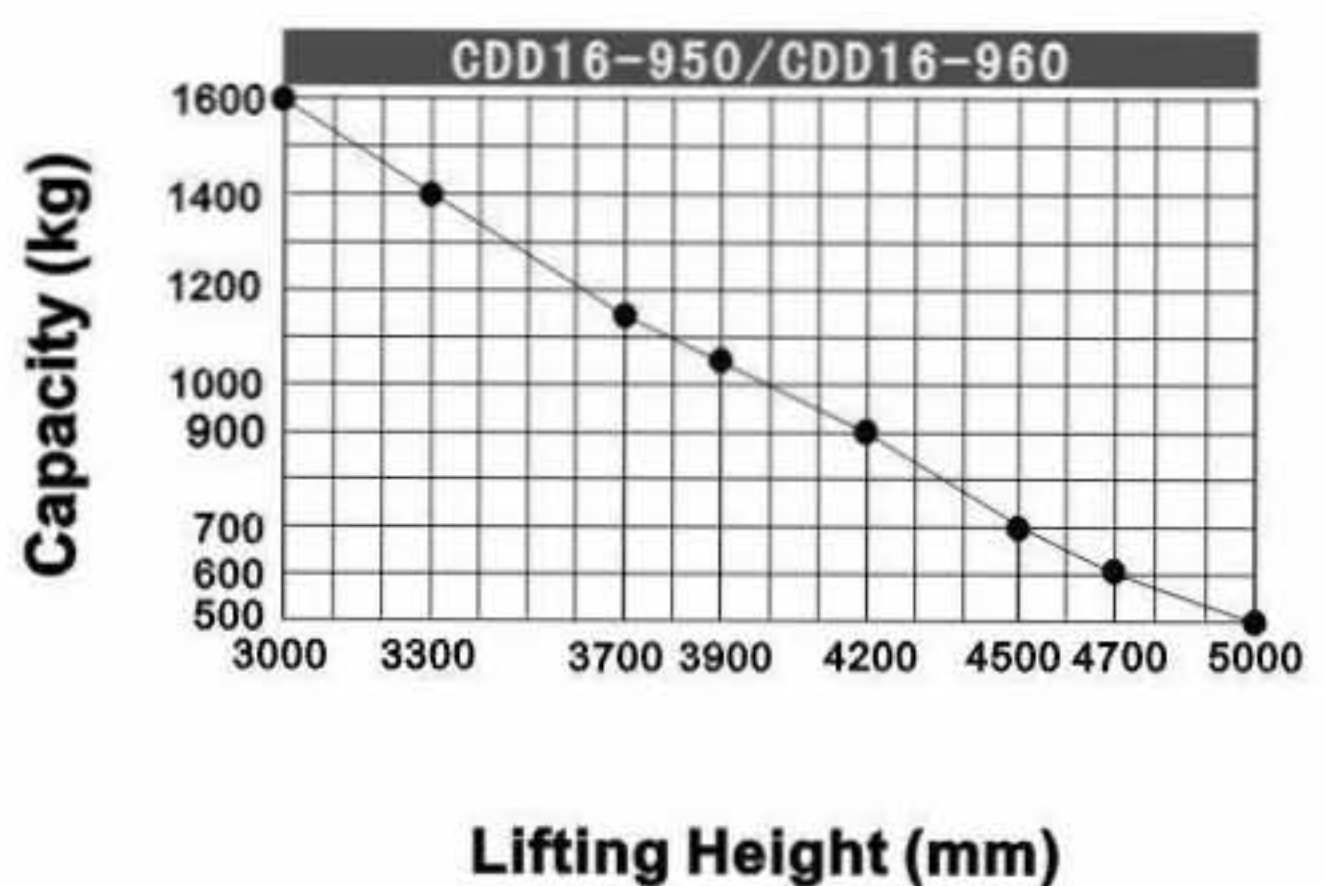
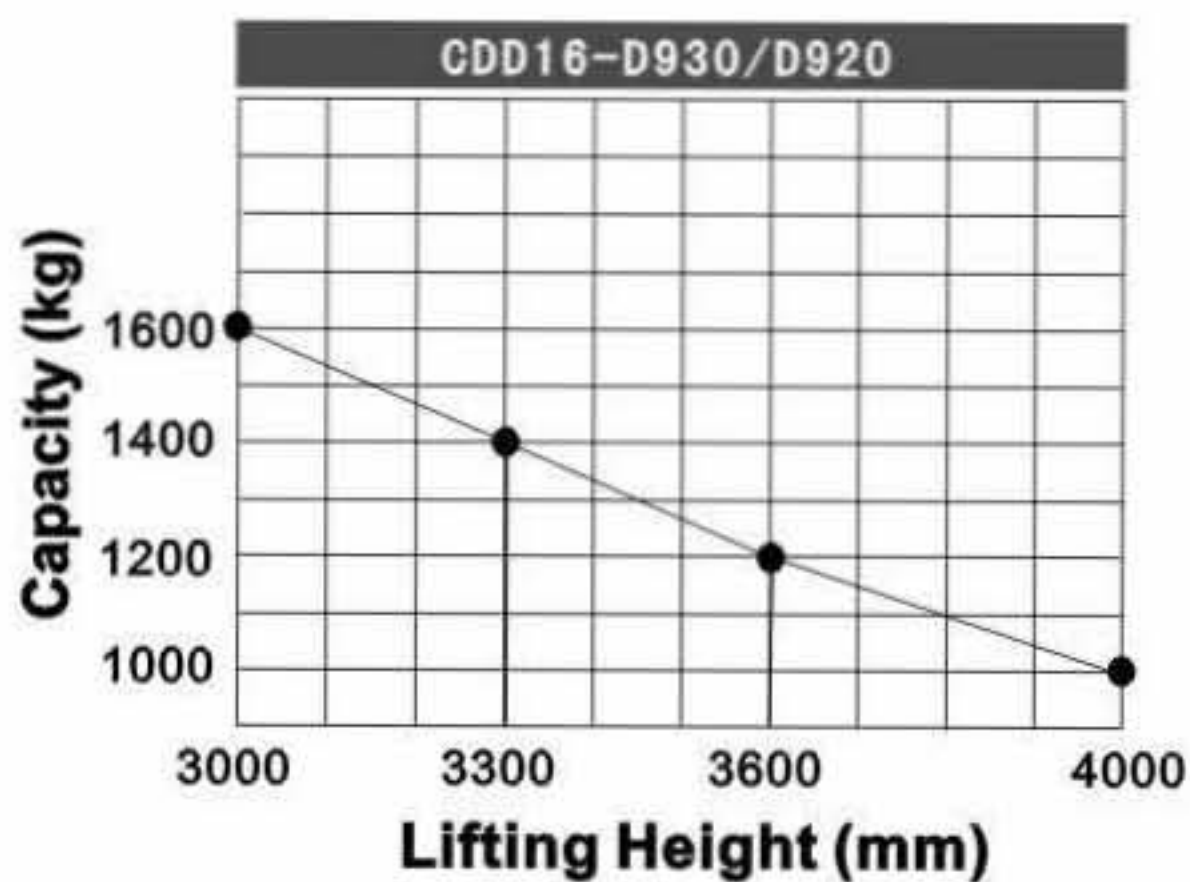
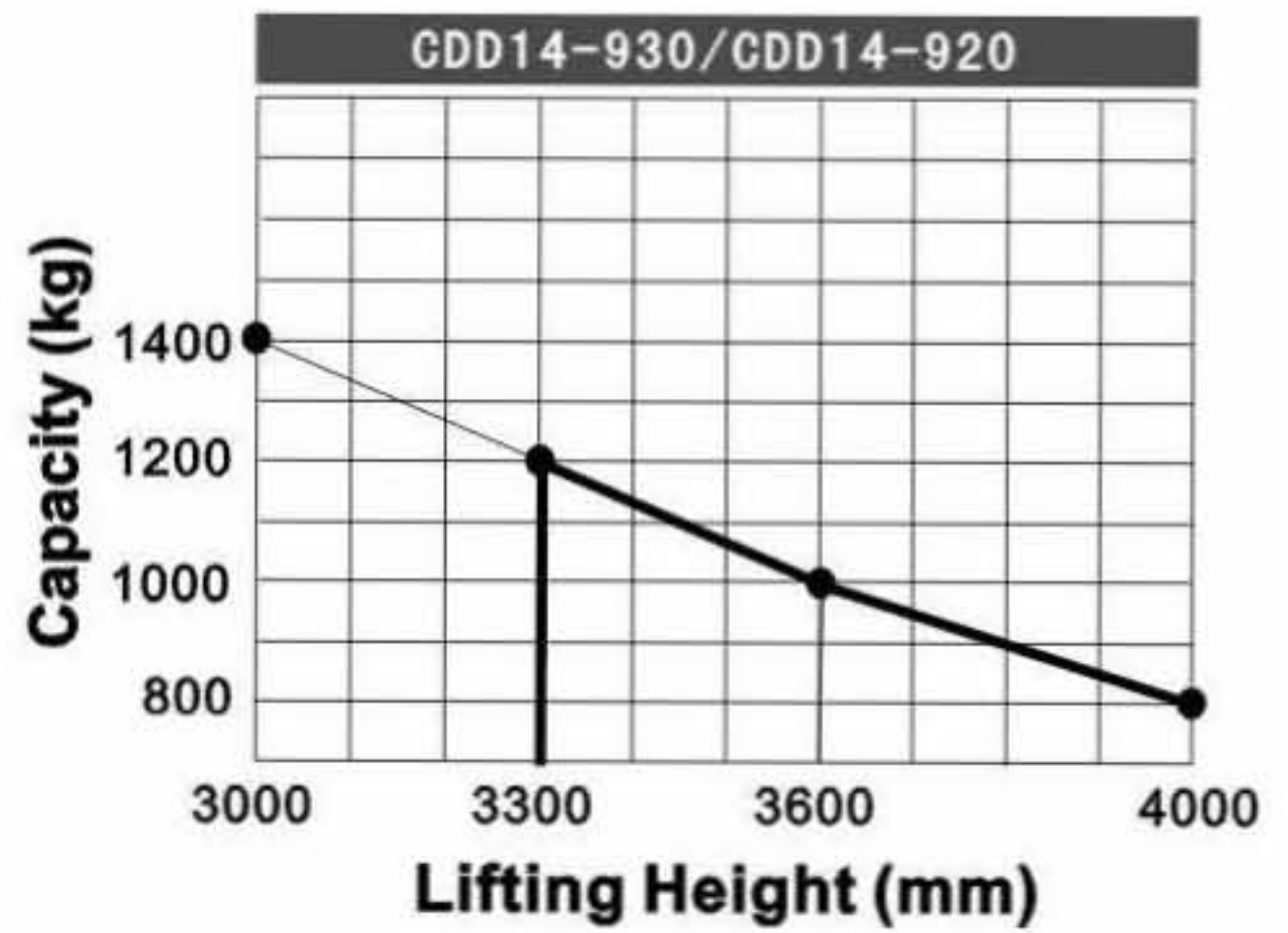
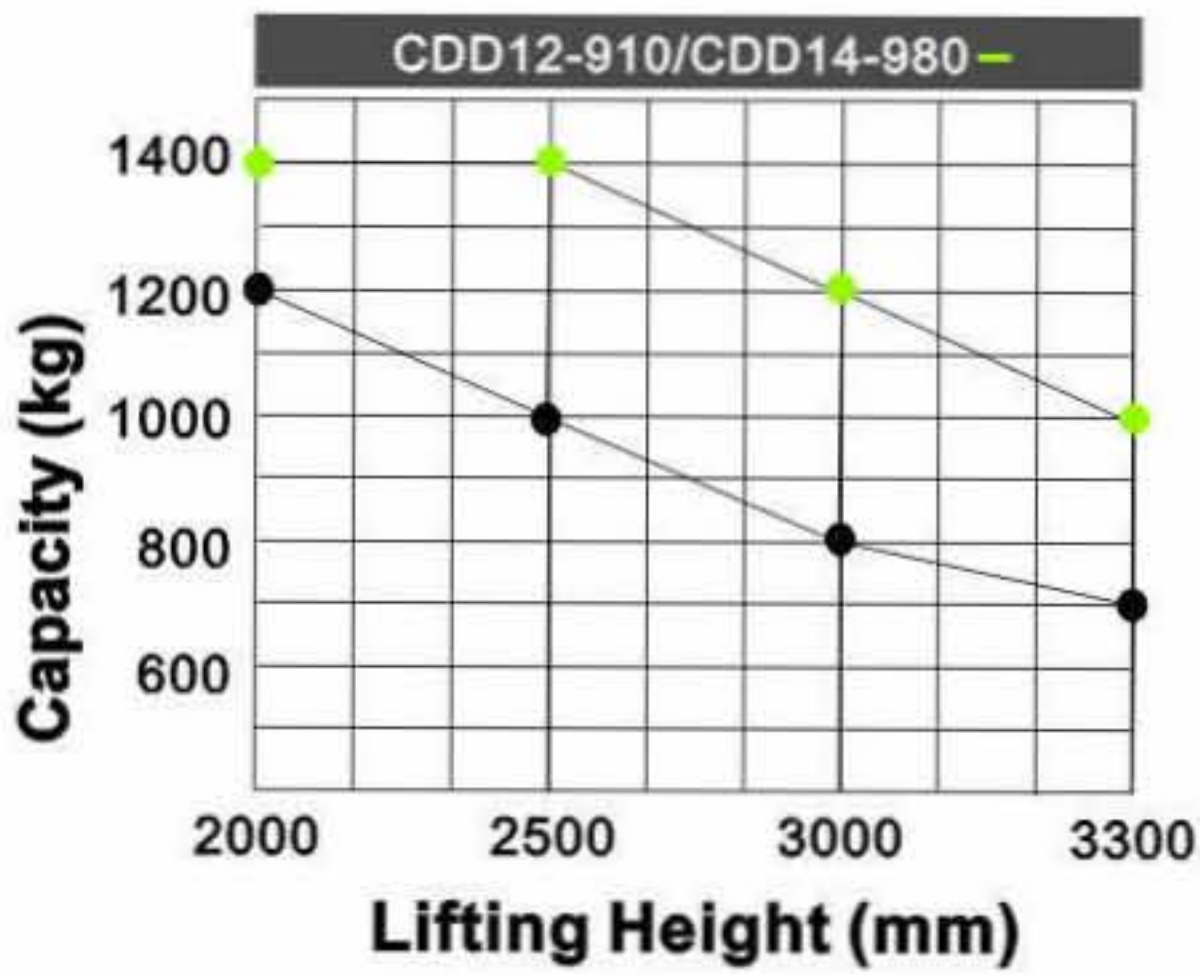
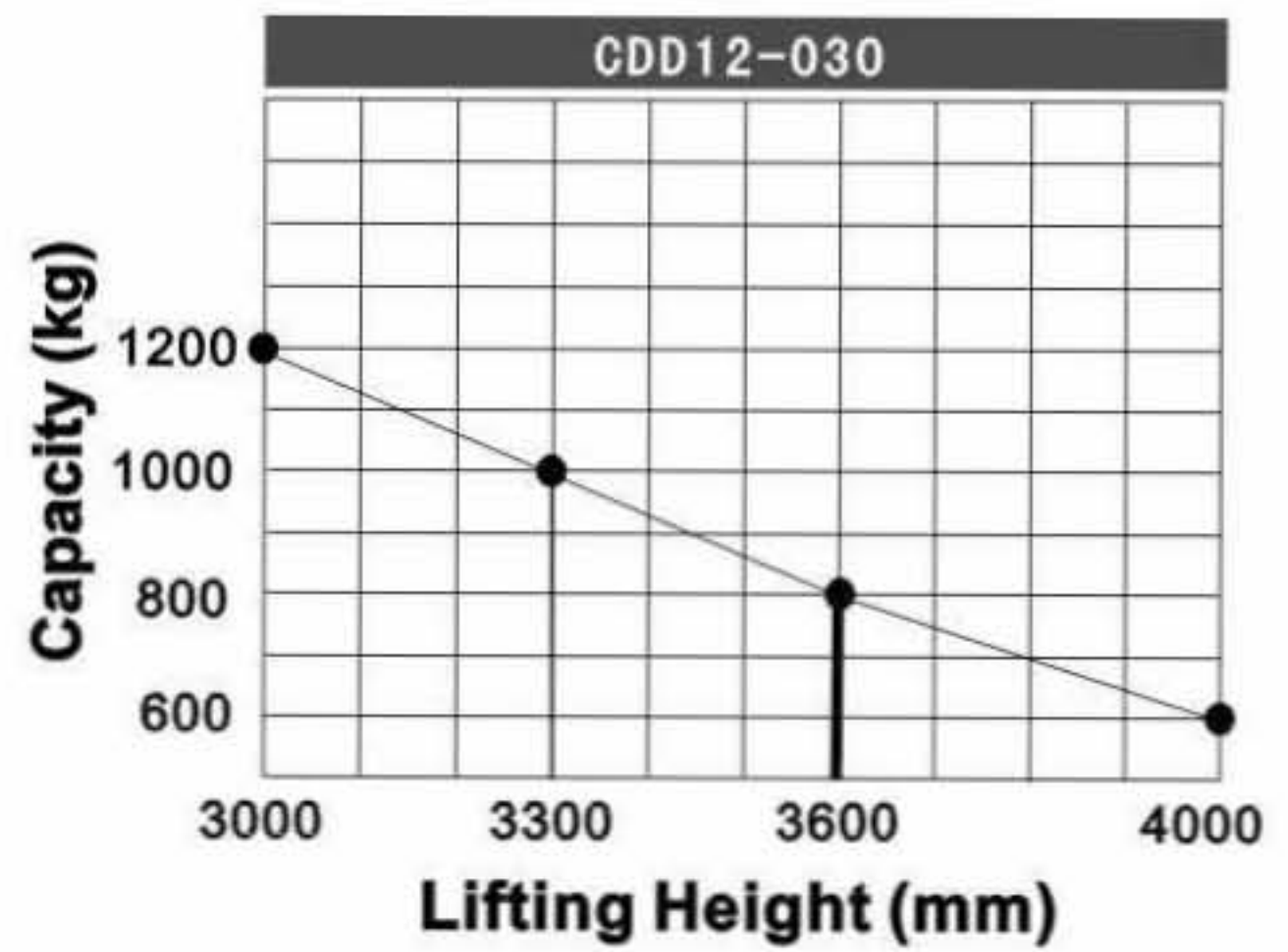
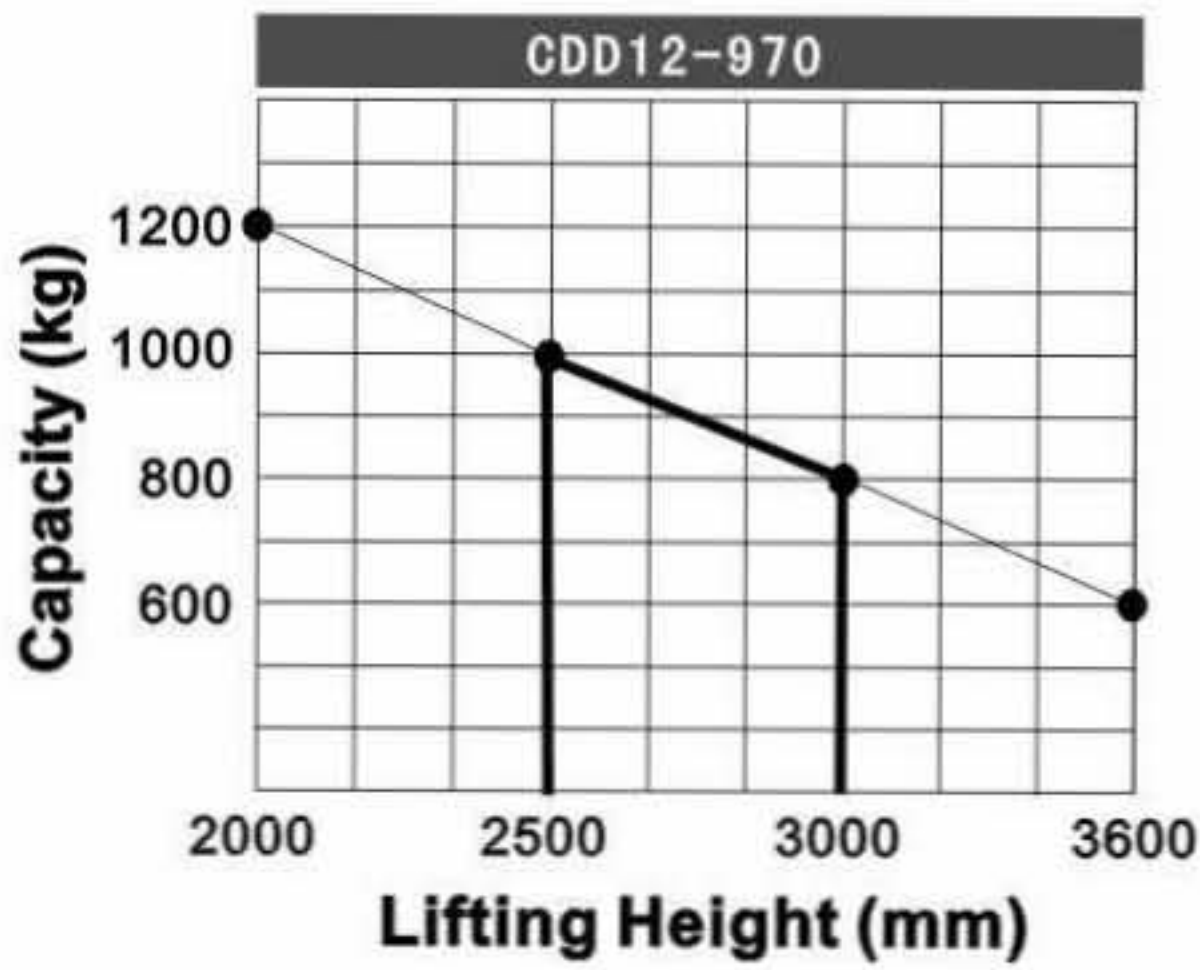





CDD12-970

1200Kg Counterbalanced /2-Stage Mast



CDD14-930

1400Kg Narrow Legs /2-Stage Mast



CDD16-D930

1600Kg Narrow Legs/2-Stage Mast



CDD12-910

1200Kg Counterbalanced /Full Free 2-Stage Mast



CDD14-980

1400Kg Narrow Legs /Full Free 2-Stage Mast



CDD16-950

1600Kg Narrow Legs/Full Free 3-Stage Mast



CDD12-030

1200Kg Narrow Legs /2-Stage Mast



CDD14-920

1200Kg Wide Legs /2-Stage Mast



CDD16-D920

1600Kg Wide Legs/2-Stage Mast



## Electric Pallet Truck Technical Specifications

Feature												
1	Model		CDD12	CDD12	CDD12	CDD14	CDD14	CDD14	CDD16	CDD16	CDD16	CDD16
2	Configuration No.		970	910	030	930	920	980	D930	D920	950	960
3	Type		Counterbalance		Narrow legs		Wide legs	Narrow legs		Wide legs	Narrow legs	Wide legs
4	Mast type		2-Stage STD	Full free 2-Stage	2-Stage STD			Full free 2-Stage	2-Stage STD		Full free 3-Stage	
5	Load capacity	kg	1200			1400			1600			
6	Load center	mm	500			600						
7	Wheel base	mm	1179		1270	1325	1310	1325	1310		1375	
8	Operating type		Rider / Pedestrian									
Wheels												
9	Wheels type		PU									
10	Wheels quantity		Driving wheel1/Load wheel2			Driving wheel1/Balance wheel2/Load wheel4						
Dimension												
11	Standard lift height	mm	3000								4500	
12	Lowered fork height	mm	55		85	55	85	55	85	55	85	55
13	Fork size(Length/width/thickness)	mm	1070/100/40		1150/185/55		1070/100/40		1150/185/55		1070/100/40	
14	Overall length	mm	2502/3012		1993/2413	2050/2470	2005/2425	2050/2470		2005/2425	2105/2525	2073/2493
15	Overall width	mm	1015		812	856	1470	856		1470	957	1470
16	Max. extend height	mm			4000	3600	3500			5000		
17	Mast lowered height	mm			2030	2080	1980		2080	1980	2085	
18	Min. Turning radius	mm	1352/1852		1525/1935	1580/1990	1565/1975	1580/1990		1565/1975	1630/2040	
19	Min. Aisle width for pallets 800X1200	mm	2685/3175		2130/2520	2180/2580	2230/2580	2180/2580		2230/2560	2230/2625	
20	Min. Aisle width for pallets 1000X1200	mm	2715/3195		2160/2540	2210/2600	2260/2585	2210/2600		2260/2585	2260/2650	
21	Min. ground clearance	mm	80		30		50	30		50	30	50
Performance												
22	Travel Speed,laden/unladen	km/h	5/5									
23	Lift speed,laden/unladen	mm/s	130/230									
24	Travel speed,laden/unladen	mm/s	130/230									
25	Gradeability,laden/unladen	%	5/7									
Electrical configuration												
26	Motor	KW	Drive motor AC1.5 / Lift motor DC3 / Steering motor DC 0.15									
27	Battery voltage	V	24									
28	Battery capacity	Ah	270		210	280						
29	Brake		Electromagnetic /Regenerative									
30	Controller		CURTIS 1230									
Weight												
31	Battery weight	Kg	245	190	235							
32	Service weight with Battery	Kg	1800	1930	1110	1204	1300	1330	1240	1370	1578	1648





## Product Advantage



Power steering system  
Very easy operating  
Curtis controller  
AMP connectors  
NSK bearings



Vertical drive system  
Driving Floating Adjustable system design  
Maintenance free AC motor provides  
stronger power and enhances gradeability.



Power boost cylinder prevents wheel skid



Open inner-structure, numbered wire  
harness in clear layout



Electronic lift limitation switch  
ensures safety and  
energy-saving.



Side-extraction battery  
More convenience



Automatic reset handle  
and pedal by gas springs,  
Reduce mechanical shock.  
Three descent speed  
Descending fast without  
load and slow with load



CNC machining ensures machining  
precision.

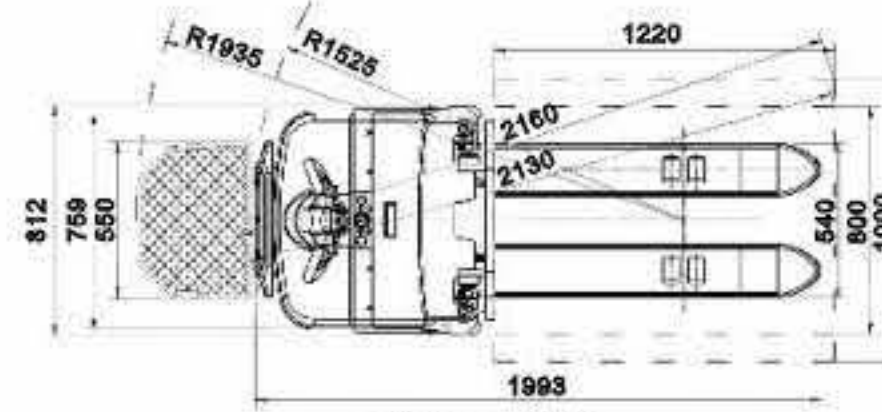
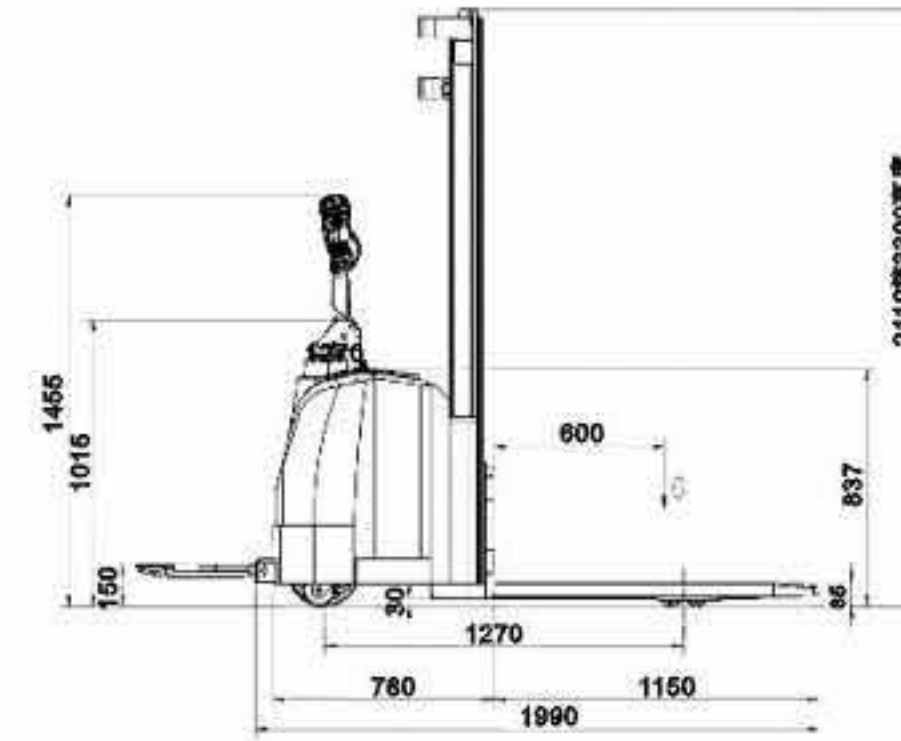

CDD12-030

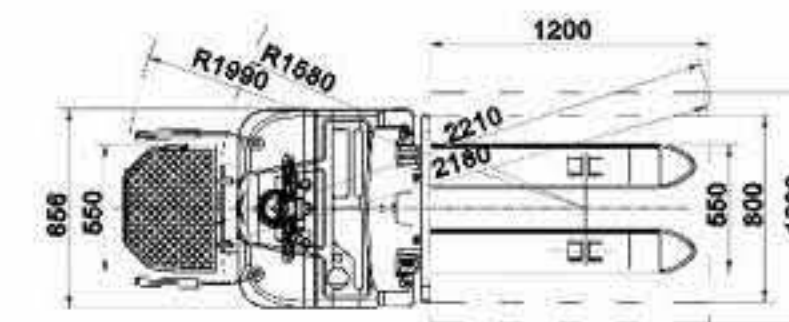
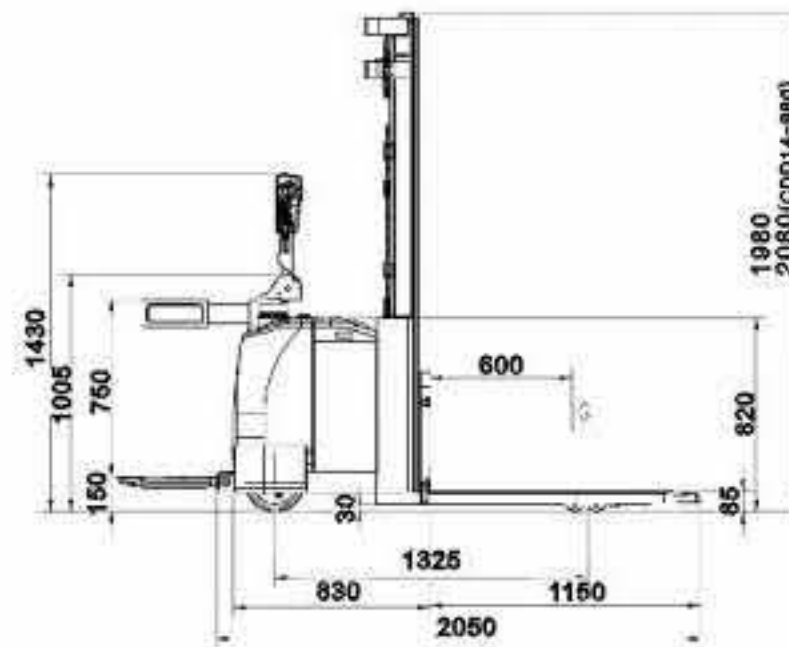

CDD14-930  
CDD14-980  
CDD16-D930

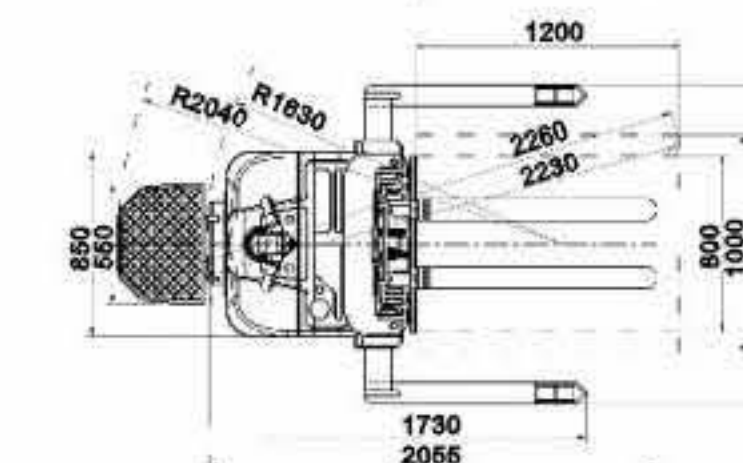
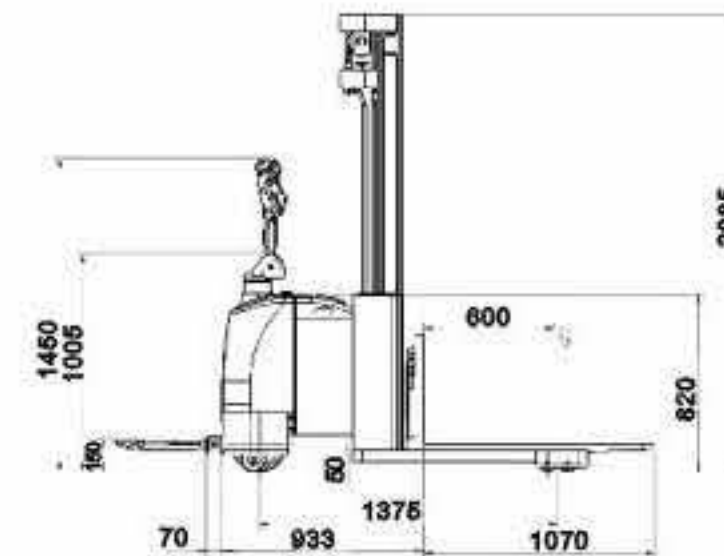

CDD16-960

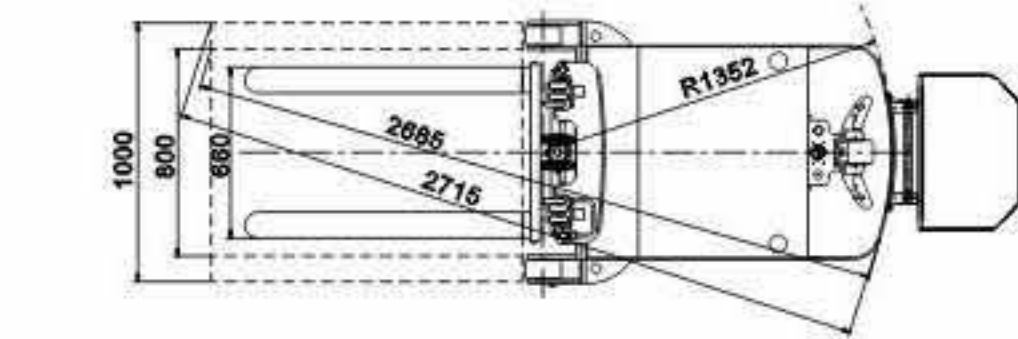
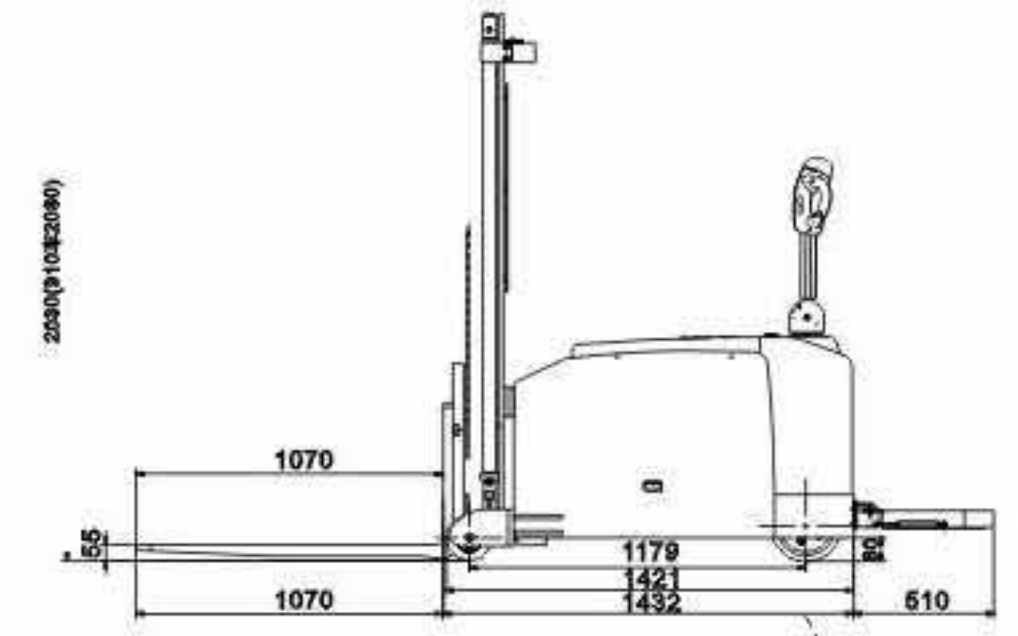

CDD12-970  
CDD12-910

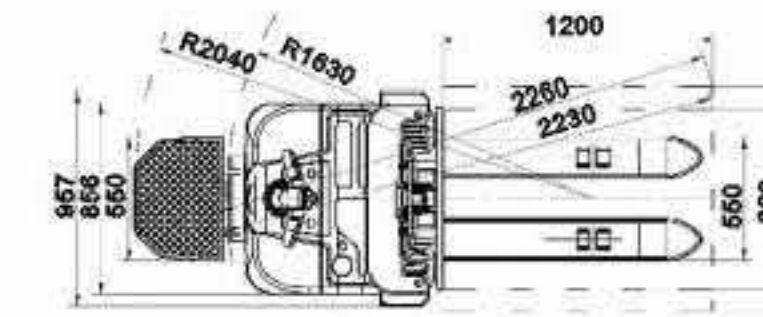
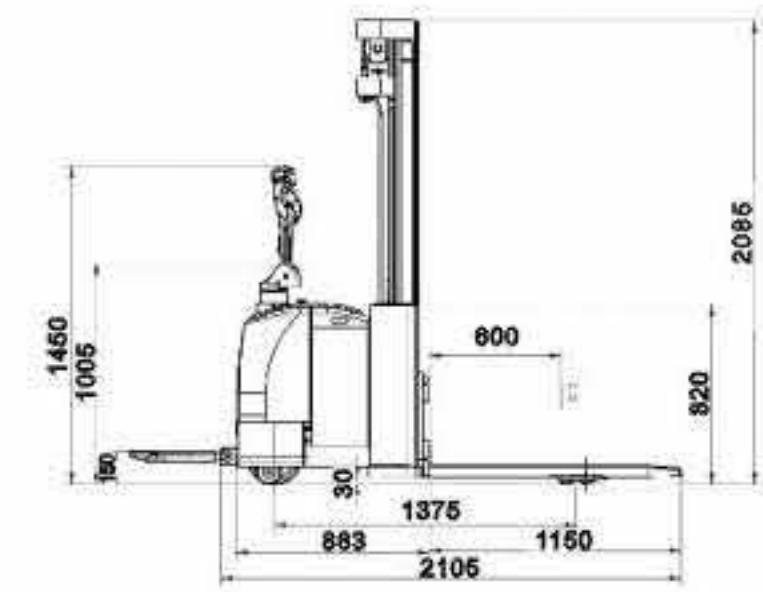

CDD16-950

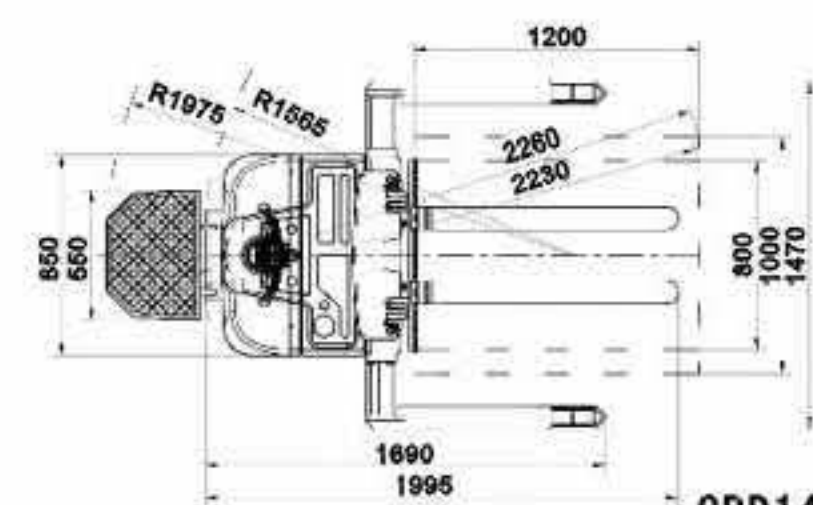
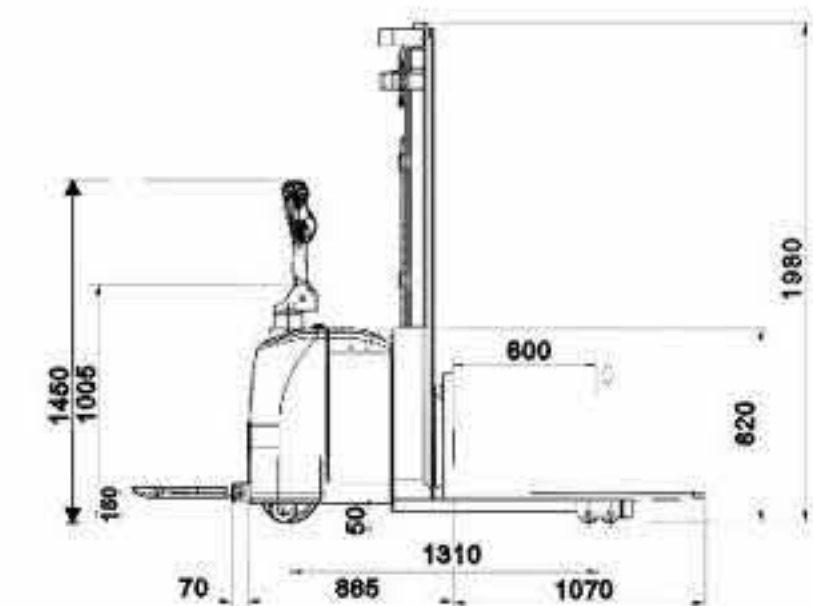

CDD14-920  
CDD16-D920



## CDD 12-970 (2-STAGEMAST)

Mast model	Max. lift height (mm)	Load capacity (kg)	Mast lowered height (mm)	Max. extend height (mm)	Tilt angles
M140	1400	1200	1230	2400	3/5
M200	2000	1200	1580	3000	3/5
M250	2500	1000	1780	3500	3/5
M300	3000	800	2030	4000	3/5
M330	3300	700	2130	4300	3/5
M360	3800	600	2330	4000	3/5

## CDD 12-910 (FULL FREE 2-STAGEMAST)

Mast model	Max. lift height mm	Load capacity (kg)	Mast lowered height (mm)	Max. extend height mm	Free lift height (mm)
ZM250	2500	1000	1830	3100	1270
ZM300	3000	800	2080	3600	1520
ZM330	3300	700	2180	3900	1620

## CDD 12-D30 (2-STAGEMAST)

Mast model	Max. lift height (mm)	Load capacity kg	Mast lowered height (mm)	Max. extend height (mm)
M200	2000	1200	1535	2500
M250	2500	1200	1765	3000
M300	3000	1200	1880	3500
M330	3300	1000	2135	3800
M360	3000	800	2335	4100
M400	4000	600	2500	4500

## CDD 14-980 (FULL FREE 2-STAGEMAST)

Mast model	Max. lift height (mm)	Load capacity (kg)	Mast lowered height (mm)	Max. extend height (mm)	Free lift height (mm)
ZM250	2500	1400	1830	3000	1270
ZM300	3000	1200	2080	3500	1520
ZM330	3300	1000	2180	3800	1620

## CDD 14-920, CDD 14-930/CDD 16-D920, CDD 16-D930 (2-STAGEMAST)

Mast model	Max. lift height mm	Load capacity/kg		Mast lowered height (mm)	Max. extend height (mm)
		920/930	D920/D930		
M140	1400	1400	1600	1185	1900
M200	2000	1400	1600	1535	2500
M250	2500	1400	1600	1765	3000
M300	3000	1400	1600	1980	3500
M330	3300	1200	1400	2135	3800
M300	3600	1000	1200	2335	4100
M400	4000	800	1000	2500	4500

## CDD 16-950/CDD 16-D960 (FULL FREE 3-STAGEMAST)

Mast model	Max. lift height (mm)	Load capacity (kg)	Mast lowered height (mm)	Max. extend height (mm)	Free lift height (mm)
ZSM370	3700	1150	1800	4200	1335
ZSM390	3900	1050	1900	4400	1448
ZSM420	4200	900	1985	4700	1520
ZSM450	4500	700	2085	5000	1620
ZSM470	4700	600	2135	5200	1670
ZSM500	5000	500	2235	5500	1770





Red font is standard configuration/ Blue font is optional configuration

NO	Model	Fork length (mm)	Straddle leg OD (mm)	Overall fork width(mm)	Protection arm	Pedal	Organic glass net	Altitude speed limited	Curve low speed	Low TEMP	Tilt	FAAM Ah Battery
1	CDD12-970	920/1070		200-660	-	●	●	●	●	●	●	270
2	CDD12-910	1150/1200	1015		-	●	●	●	●	●	-	
3	CDD12-030	1150/1220	550/600/650/685	200-812	●	●	●	●	●	●	-	210
4	CDD14-930				●	●	●	●	●	●	●	
5	CDD14-920	920/1070 1150/1200	1170/1320/1470	200-812	●	●	●	●	●	●	-	270
6	CDD14-980	1150/1220	550/600/650/685	200-812	●	●	●	●	●	●	-	
7	CDD16-D930				●	●	●	●	●	●	●	
8	CDD16-D920	920/1070 1150/1200	1170/1320/1470	200-812	●	●	●	●	●	●	-	
9	CDD16-950	1150/1200	550/600/650/685	200-812	●	●	●	●	●	●	-	
10	CDD16-960	920/1070 1150/1200	1320/1470	200-812	●	●	●	●	●	●	-	

TOP 10 FORKLIFT MANUFACTURER IN THE WORLD  
NO.1 IN CHINA MARKET FOR THE 22 CONSECUTIVE YEAR

## ANHUI HELI INDUSTRIAL VEHICLE IMPORT&EXPORT CO.,LTD.

ADDR 15 WEST WANGJIANG ROAD,HEFEI,ANHUI,P.R.CHINA

TEL (86 551)63639068,63639258,63639358

FAX (86 551)63639966

WEBSITE <http://www.helichina.com>

AUTHORIZED DEALER

\* Details of specifications and equipment are based on information available at the time of printing and may change without notice.

© 2013 heli copyright

Catalog No.2013.03

HELI Print