

NOTE:  
Vertical axle stands for load capacity while horizontal axle stands for load center. Load center is the distance counted from the front of the fork. The base point of the standard load is the center point of the cubic with the same 1200mm dimension in length, width and height. The load capacity should be down, if mask tilts forward, using non-standard forks or loading goods with extra width. Please notice the different load capacity between different load centers according to load chart.

— CPCD45 — CPCD50  
— CPCD55 — CPCP40

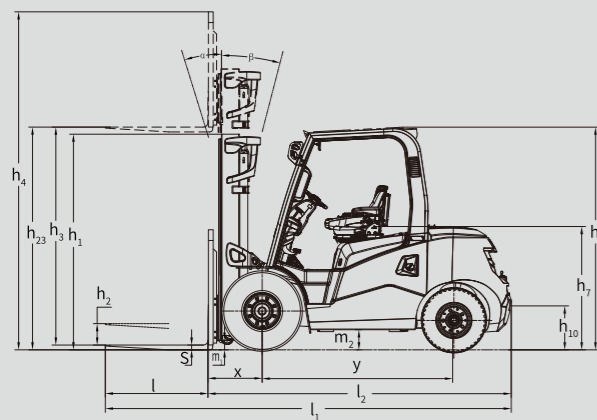
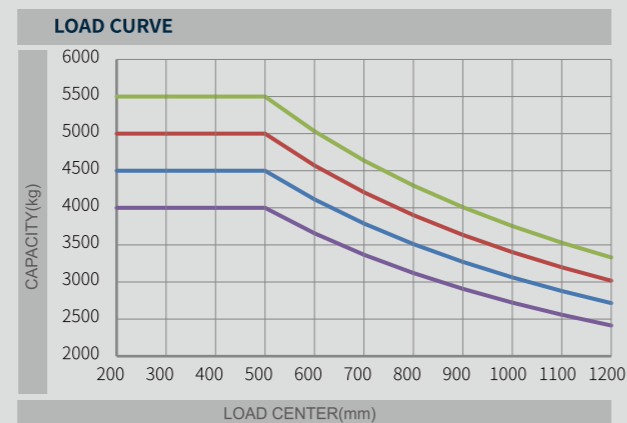

**Standard configuration**

- Reversing handle (with horn)
- Protection sleeve for steering cylinder
- LED lights
- File folder
- HEAN semi enclosed seat
- Middle wide angle rear view mirror
- Median exhaust
- Steering wheel with handle ball
- Counter weight protection net
- Adjustable steering wheel
- Ratchet parking brake
- Flexible connection casting steering axle
- Stamping overhead guard
- Electric-hydraulic reversing control
- Air filter with safety filter element
- LCD instrument

**Optional configuration**

- Warming light
- Cab
- Two stage free lift mast and three stage free lift mast
- Dual tyre of front wheel and solid tyre
- Thread
- Synchronized steering system
- Rear view mirrors on both sides
- Dual hose pulley block
- High exhaust
- Double air filter
- Rear lamp
- Protection sleeve for tilt cylinder
- GRAMMER'S full suspension seat
- Air conditioner
- Heater
- OPS control system
- Fire extinguisher
- Fan
- Reversing horn speaker
- Coarse filter
- Over speed alarm
- Automatic weight system, overload alarm
- Rear view system
- Truck networking



**4-5.5 t**  
G3 series Internal Combustion Counterbalanced Forklift Truck



**ANHUI HELI CO., LTD.**  
Add / No.668, FangXing Road, Hefei, China  
Fax / +86-551-63639966  
Tel / +86-551-63639068 (North America); 63634335 (Latin America);  
63639258 (Europe); 63639358 (Asia); 63662105 (Africa& Middle East);  
63648352 (Eurasia); 63629143 (Oceania)  
E-mail / heli@heliforklift.net



LinkedIn



YouTube



Facebook

FC(G3)003 EN Design&Print:Fokell/Printing\_20251127

\* Our products are subject to improvements and changes without notice.

# AESTHETICS / FUNCTIONAL

A Design Of Perfect Combination



## A NEW GENERATION OF PRODUCTS

Intelligent / Safe / Efficient / Saving and Environment Friendly

## COMFORTABLE OPERATION

New family PI image design, appearance upgrade, optimized structure design and high-end configuration ensure comfortable operation from every detail.



Flexible connected intelligent shift hydraulic transmission has been verified by market for 30 years and has the features of mature and reliable, small vibration, convenient and comfortable operation;



The standard configuration of electro-hydraulic reversing and steering handle and lamp combination handle improves the operation convenience;

- High quality damping system matched with professional calculation make the idle vibration isolation rate up to 68%; high quality Hutchinson damping pad is adopted and has the features of more stable damping effect and longer service life;



The tilt cylinder sinks to improve the leg space;



Full LCD color display CAN bus instrument fully monitors truck status; displays real-time engine and truck fault information and gives humanized reminder;



Wide view mast optimizes the blind area of operation vision and ensures comfortable and safe operation;



Standard configuration of mast lowering buffer makes it more comfortable to handle goods;



- The ratchet type parking brake handle is more labor-saving.
- Increased handle with leather anti-skid makes getting on and off more convenient; Reversing handle with horn makes truck reversing safer.

## ENERGY SAVING AND ENVIRONMENT FRIENDLY

- Standard configuration of load sensing gives priority to steering and saves energy by 5%.
- The dual pump combined hydraulic system can supply flow on demand and reduce truck fuel consumption;
- Standard configuration of LED lights make truck more energy saving ,environment friendly,long life using and reliable.

## HIGHER EFFICIENCY

- Enlarged high air intaking grid makes air intake smoother and engine power utilization more sufficient.
- Tail-free frame reduces truck center of gravity and improves truck lateral stability and bearing capacity at high.

Faster lifting and lower speed	Faster travelling speed
Stronger drawbar pull	Good load capacity at high lift



## SAFE AND RELIABLE

- The standard hydraulic power assisted braking system has stronger tolerance to working environment (such as dust) and stable and reliable braking performance;
- The electro-hydraulic reversing box and control box are mature and reliable, and the pipeline layout is optimized to effectively reduce the failure rate of electrical components;
- The waterproof connector is safe and reliable;
- Increased pipe diameter of hydraulic system reduces the pressure loss and extends the service life of hydraulic components;
- Increase the aluminum plate fin radiator controls temperature in a good range and effectively improves the reliability of each system;
- The standard 8-inch air filter with safety filter element is equipped with air filter blockage alarm device to remind the maintenance of the air filter in time, protect the engine and improve the reliability of the engine;



- Equipped with cast steering axle, the strength of the axle body is increased by 30%, and the standard protective sleeve is provided;
- High strength integral welded overhead guard improves driving safety factor;
- The balance weight is optimized to improve the rear field of view and ensure the safety of operation;
- The rear wheels are equipped with Zhengxin 14-layer tires as standard to improve the service life of tires;
- The metal step is anti-skid, reliable and durable;
- The optimized brake can effectively prevent locking after rain, reduce braking impact, extend the service life of the brake, prevent excessive braking, and significantly improve the reliability and service life.

High strength integral welded overhead guard improves driving safety factor;

### HELI smart fleet management system (optional)

Vehicle positioning	Vehicle management
Remote diagnosis	Identification recognition (optional)
Remote monitoring	Weight management (optional)
Maintenance reminder	Collision management (optional)
Statistical form	

## EASY MAINTENANCE

- 80° opening angle, easy opening mechanism and optional key lock make repair and maintenance easy.
- Module design of electric system reduces maintenance cost.

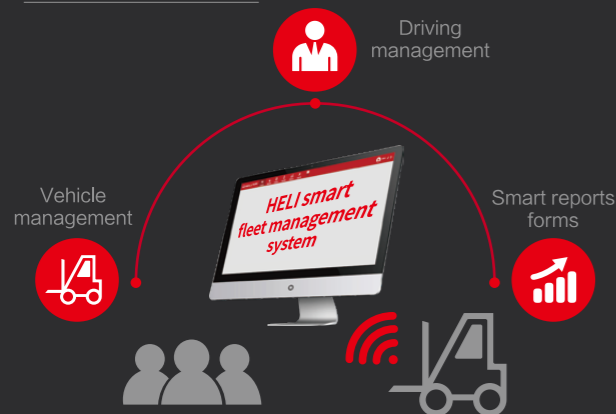

Manufacturer and Technical Data							
Characteristics							
1.01	Manufacturer		<b>HELI</b>				
1.02	Model		CPCD40-*	CPCD45-*	CPCD50-*	CPCD55-*	
1.03	Configuration number		QC7G3				
1.04	Rated capacity	Q	kg	4000	4500 (4000)	5000 (4500)	5500 (5000)
1.05	Load center distance	c	mm	500 (600)			
1.06	Power mode		Diesel/LPG/Dual fuel				
1.07	Driving mode		Sit-on type				
1.08	Front overhang	x	mm	560			
1.09	Wheelbase	y	mm	2100			
Weight							
2.01	Total weight		kg	6250	6510	6920	7280
2.02	Axle load (laden,front/rear)		kg	9110/1140	9840/1170(9280/1230)	10540/1370(10000/1420)	11270/1510(10760/1520)
2.03	Axle load (unladen,front/rear)		kg	3100/3150	3080/3430	3030/3890	3010/4270
Tyres							
3.01	Tyre type		Pneumatic type				
3.02	Tyre size,front		8.25-15-14PR 300-15-18PR ( Double-tyre 8.25-15-14PR)				
3.03	Tyre size,rear		7.00-12-14PR 7.00-12-14PR				
3.04	Wheels,number front/rear (x=driven wheels)		2X/2(Double-tyre 4X/2)				
3.05	Tread, front	b <sub>10</sub>	mm	1210			
3.06	Tread, rear	b <sub>11</sub>	mm	1190			
Dimensions							
4.01	Mast tilt angle (forward/backward)	α/β	°	6/12			
4.02	Height (mast lowered)	h <sub>1</sub>	mm	2250			
4.03	Free lifting height	h <sub>2</sub>	mm	150			
4.04	Lifting height (standard)	h <sub>3</sub>	mm	3000			
4.05	Max. height,extended (with backrest)	h <sub>4</sub>	mm	4250	4405		
4.06	Height of overhead guard	h <sub>5</sub>	mm	2350			
4.07	Seat height relating to SIP (to ground)	h <sub>7</sub>	mm	1080			
4.08	Towing coupling height	h <sub>10</sub>	mm	430			
4.09	Overall length (with fork)	l <sub>1</sub>	mm	4255	4275 (4425)	4325 (4475)	4375 (4525)
4.10	Overall length (without fork)	l <sub>1</sub>	mm	3185	3205	3255	3305
4.11	Overall width	b <sub>1</sub>	mm	1525			
4.12	Fork size:thickness x width x length	s/e/l	mm	50x150x1070	50x150x1070 (50x150x1220)	50x150x1070 (50x150x1220)	55x150x1070 (55x150x1220)
4.13	Fork carriage,according to ISO2328			III		IV	
4.14	Distance across fork-arms, Max./Min.	b <sub>5</sub>	mm	1374/300			
4.15	Ground clearance (laden,between mast)	m <sub>1</sub>	mm	120			
4.16	Ground clearance (center of wheelbase)	m <sub>2</sub>	mm	220			
4.17	Right angle stacking aisle width for pallet 1000 x1200mm crossways	Ast	mm	4610	4640	4690	4740
4.18	Right angle stacking aisle width for pallet 800 x1200mm lengthways	Ast	mm	4810	4840	4890	4940
4.19	Min. outside turning radius	Wa	mm	2850	2880	2930	2970
Performance Data							
5.01	Travel speed (laden/unladen)		km/h	25/26			
5.02	Lift speed (laden/unladen)		m/s	0.58/0.62	0.53/0.58		
5.03	Lowering speed (laden/unladen)		m/s	0.45			
5.04	Max.drawbar pull (laden/unladen)		N	41/25			
5.05	Max.gradeability (laden/unladen)		%	33/28	30/28	33/28	30/28
Combustion-engine							
6.01	Engine manufacturer/Moel		QUANCHAI 4C6-88C31 BOSCH HPCR				
6.02	Rated power/Speed		kW/rpm	65/2200			
6.03	Max. torque/Speed		Nm/rpm	350/1800			
6.04	Cylinder number-bore x stroke		4-98mmx115mm/3.47L				
6.05	Engine displacement		L	3.47			
6.06	Emission		China stage III				
6.07	Transmission gears (front/rear)		2/1 Intelligent gear shifting				
6.08	Fuel tank capacity		L	110			
Addition data							
7.01	Service brake/Parking brake		Hydraulic assisted braking/ Mechanical-ratchet type				
7.02	Operating pressure for attachments		Mpa	14			

## Engine model and main specification technical data for option

Engine model	Power mode	Model	Rated power/Speed (kW/rpm)	Max. torque/Speed (Nm/rpm)	Engine displacement (L)	Cylinder number-bore x stroke	Emission
QUANCHAI 4C6-88C31 BOSCH HPCR	Diesel	CPCD40-55-QC7G3	65/2200	350/1800	3.47	4-98x115	China Stage III
Mitsubishi s6s	Diesel	CPCD40-55-M4G3	52/2300	248/1700	4.996	6-94x120	China Stage III/Euro III A
Kubota Certified WG3800	LPG	CPYD40-55-KUG3	59/2400	282/1200	3.768	4-100x120	Euro V
Kubota Certified WG3800	LPG&GAS	CPQYD40-55-KUG3	50.6/2400	271(LPG)/1200 246(GAS)/1400	3.768	4-100x120	Euro V
Kubota Non certified WG3800	LPG	CPYD40-55-KU2G3	63.2/2400	282/1200	3.768	4-100x120	Non certified
Kubota Non certified WG3800	LPG&GAS	CPQYD40-55-KU2G3	59.9(LPG)/2400 56.8(GAS)/2400	271(LPG)/1200 247(GAS)/1400	3.768	4-100x120	Non certified

## Wide View Standard Mast

Mast model	Max.lifting height (mm)	Load capacity (lode center 500mm)(kg)				Height (mast lowered) (mm)	Free lift height (with backrest) (mm)	Service weight (kg)				Mast tilt angle α/β (°)
		4t	4.5t	5t	5.5t			4t	4.5t	5t	5.5t	
M250	2500	4000	4500	5000	5500	2000	150	6200	6460	6870	7230	6°/12°
M300	3000	4000	4500	5000	5500	2250	150	6250	6510	6920	7280	6°/12°
M330	3300	4000	4500	5000	5500	2400	150	6280	6540	6950	7310	6°/12°
M350	3500	4000	4500	5000	5500	2500	150	6300	6560	6970	7330	6°/12°
M370	3700	4000	4500	5000	5500	2600	150	6315	6575	6985	7345	6°/12°
M400	4000	4000	4500	5000	5500	2800	150	6390	6650	7060	7420	6°/12°
M425	4250	4000	4500	5000	5500	2925	150	6415	6675	7085	7445	6°/6°
M450	4500	4000	4500	5000	5500	3050	150	6435	6695	7105	7465	6°/6°
M475	4750	3900	4400	4700	5000	3175	150	6460	6720	7130	7490	6°/6°
M500	5000	3800	4300	4600	4900	3300	150	6485	6745	7155	7515	6°/6°
M550	5500	*3000 *3500	*3400 *3900	*3800 *4300	*4200 *4600	3600	150	6575	6835	7245	7605	6°/6°
M600	6000	*3400	*3700	*4100	*4500	3850	150	6625	6885	7295	7655	6°/6°

## Wide View Full Free 2-Stage Mast

Mast model	Max.lifting height (mm)	Load capacity (lode center 500mm)(kg)				Height (mast lowered) (mm)	Free lift height (with backrest) (mm)	Service weight (kg)				Mast tilt angle α/β (°)	
		4t	4.5t	5t	5.5t			4t	4.5t	5t	5.5t		
ZM250	2500	4000	4500	5000	5500	2000	785	640	6155	6415	6825	7290	6°/12°
ZM300	3000	4000	4500	5000	5500	2250	1035	890	6215	6475	6885	7350	6°/12°
ZM330	3300	4000	4500	5000	5500	2400	1185	1040	6255	6515	6925	7390	6°/12°
ZM350	3500	4000	4500	5000	5500	2500	1285	1140	6275	6535	6945	7415	6°/12°
ZM370	3700	4000	4500	5000	5500	2600	1385	1240	6300	6560	6970	7440	6°/12°
ZM400	4000	4000	4500	5000	5500	2800	1585	1440	6390	6650	7060	7535	6°/12°
ZM425	4250	4000	4500	5000	5500	2925	1710	1565	6430	6690	7100	7570	6°/6°
ZM450	4500	4000	4500	5000	5500	3050	1835	1690	6470	6730	7140	7615	6°/6°
ZM475	4750	3700	4200	4500	4800	3175	1960	1815	6510	6770	7180	7655	6°/6°
ZM500	5000	3600	4100	4400	4700	3300	2085	1940	6550	6810	7220	7695	6°/6°
ZM550	5500	*3000 *3500	*3400 *3900	*3800 *4300	*4200 *4600	3600	2385	2240	6660	6920	7330	7810	6°/6°
ZM600	6000	*3400	*3700	*4100	*4500	3850	2635	2490	6715	6975	7385	7865	6°/6°

Note:free lift for 4-5t (without backrest):+340mm; free lift for5.5t (without backrest):+425mm;

## Wide View Full Free 3-Stage Mast

Mast model	Max.lifting height (mm)	Load capacity (lode center 500mm)(kg)				Height (mast lowered) (mm)	Free lift height (with backrest) (mm)	Service weight (kg)				Mast tilt angle α/β (°)	
		4t	4.5t	5t	5.5t			4t	4.5t	5t	5.5t		
ZSM360	3600	4000	4500	5000	5500	1940	1990	730	6365	6625	7035	7520	6°/6°
ZSM400	4000	4000	4500	5000	5500	2080	2130	870	6415	6675	7085	7590	6°/6°
ZSM435	4350	3900	4400	4900	5400	2190	2240	980	6455	6715	7125	7620	6°/6°
ZSM450	4500	3800	4300	4800	5300	2240	2290	1030	6475	6735	7145	7640	6°/6°
ZSM470	4700	3700	4200	4500	4800	2305	2355	1095	6495	6755	7165	7665	6°/6°
ZSM500	5000	3600	4100	4400	4700	2440	2490	1230	6545	6805	7215	7720	6°/6°
ZSM540	5400	*3000 *3500	*3400 *3900	*3800 *4300	*4200 *4600	2590	2640	1380	6655	6915	7325	7835	6°/6°
ZSM600	6000	*3400	*3700	*4100	*4500	2790	2840	1580	6730	6990	7400	7910	6°/6°
ZSM650	6500	*3000	*3200	*3400	*3600	2990	3040	1780	6800	7060	7470	7985	6°/6°
ZSM700	7000	*2100	*2300	*2500	*2700	3165	3215	1955	6865	7125	7535	8060	6°/6°

Note:free lift for 4-5t (without backrest):+340mm; free lift for5.5t (without backrest):+425mm;